



INSTA-CHAIN™
The AUTOMATIC ICECHAIN

VSI-009
Trailer – Air-Ride Suspension

995 S 1950 W Ste. B, Springville, UT 84663 - 800-633-0699 - 801-489-9000 - (fax) 801-489-9797 - www.insta-chain.com - traction@insta-chain.com

COPY AND FAX THIS FORM TO PLACE YOUR ORDER AT - (801) 489-9797

VEHICLE SUSPENSION INFORMATION FORM (VSI)

DEALER: _____ **PLEASE DESCRIBE ANYTHING UNUSUAL ABOUT**
DLR. CONTACT: _____ **YOUR SUSPENSION: (I.E. ANY OBSTRUCTION**
CUSTOMER: _____ **WITHIN 30 INCHES OF THE AXLE.)**
CUST. CONTACT: _____
ADDRESS: _____
CITY/ STATE/ ZIP: _____
PHONE: _____ **FAX:** _____
EMAIL: _____ **6 CHAIN / 12 CHAIN P.O.#** _____

PLEASE FILL OUT ALL INFORMATION ON FORM COMPLETELY OR WE MAY BE CALLING YOU TO GET IT DIRECTLY

FOR TRAILERS WITH AIR-RIDE SUSPENSION ONLY

Suspension Make: _____

Suspension Model: _____

Tire Size: _____

_____ BT - From bottom of Axle to ground

_____ Z - Measurement between U-Bolts - Side-ways center of bolt to center of bolt.

_____ C - Measurement from center of outside U-Bolt to the bulge of tire (to do this drop a plumb-line down from center of U-Bolt, then measure straight across horizontally.)

_____ AD - Diameter of Axle

_____ Y - Measurement of U-Bolt center to center, from Front to Back.

_____ J - Measurement from bottom of air can assembly to ground. (if applicable)

_____ K - Measurement from center of axle to nearest point of Brake Can. (if applicable)

_____ W - Measurement bottom of Air-Ride plate under the Axle to the Ground. Measure from the center of the plate.

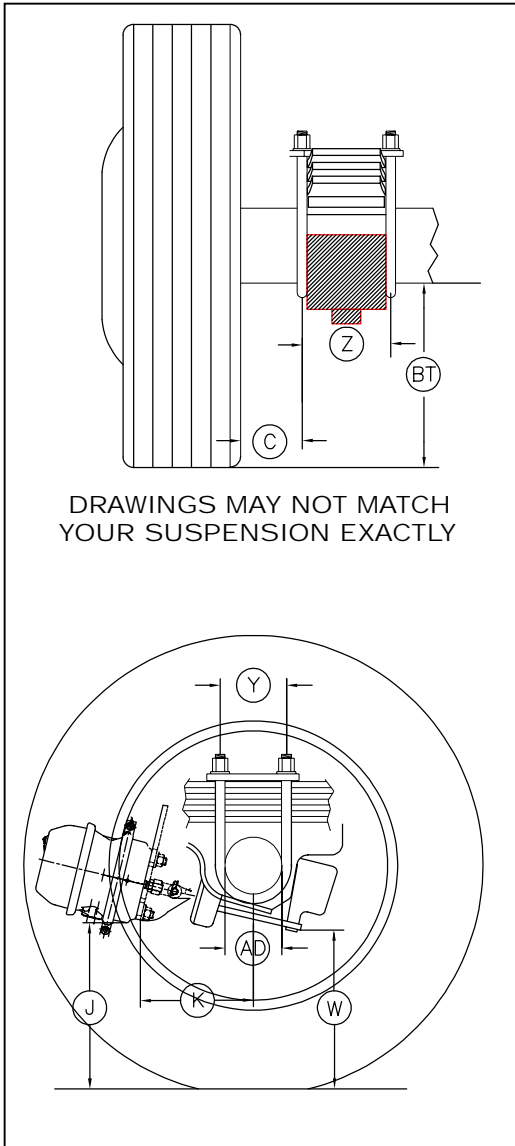

DRAWINGS MAY NOT MATCH YOUR SUSPENSION EXACTLY