



**INSTA-CHAIN™**  
The AUTOMATIC ICECHAIN

**VSI-008**  
**Trailer – Spring Suspension**

995 S 1950 W Ste. B, Springville, UT 84663 - 800-633-0699 - 801-489-9000 - (fax) 801-489-9797 - www.insta-chain.com - traction@insta-chain.com

**COPY AND FAX THIS FORM TO PLACE YOUR ORDER AT - (801) 489-9797**

**VEHICLE SUSPENSION INFORMATION FORM (VSI)**

**DEALER:** \_\_\_\_\_ **PLEASE DESCRIBE ANYTHING UNUSUAL ABOUT**  
**DLR. CONTACT:** \_\_\_\_\_ **YOUR SUSPENSION: (I.E. ANY OBSTRUCTION**  
**CUSTOMER:** \_\_\_\_\_ **WITHIN 30 INCHES OF THE AXLE.)**  
**CUST. CONTACT:** \_\_\_\_\_  
**ADDRESS:** \_\_\_\_\_  
**CITY/ STATE/ ZIP:** \_\_\_\_\_  
**PHONE:** \_\_\_\_\_ **FAX:** \_\_\_\_\_  
**EMAIL:** \_\_\_\_\_ **6 CHAIN / 12 CHAIN P.O.#** \_\_\_\_\_

PLEASE FILL OUT ALL INFORMATION ON FORM COMPLETELY OR WE MAY BE CALLING YOU TO GET IT DIRECTLY

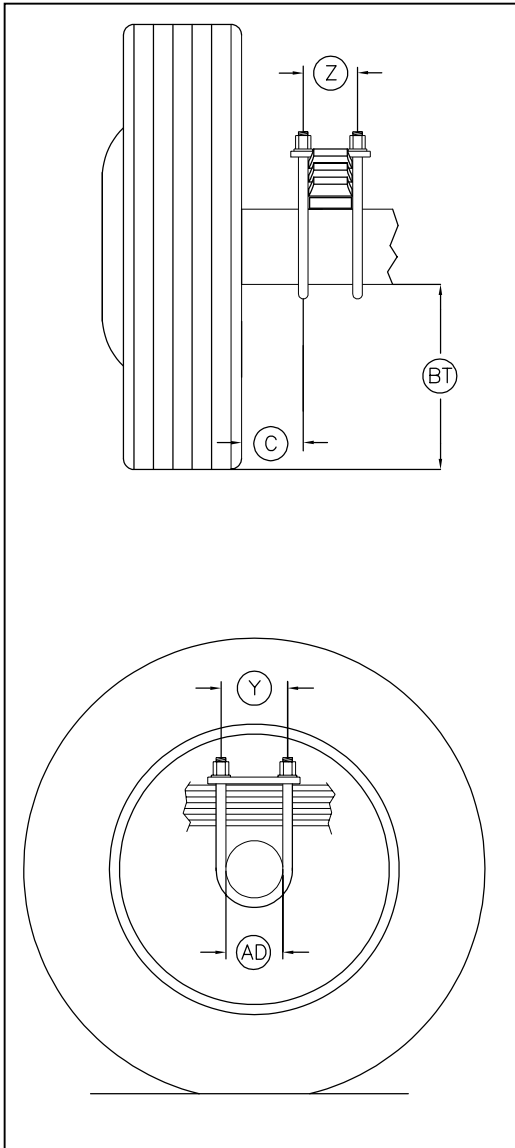

**FOR TRAILERS WITH SPRING SUSPENSION ONLY**

Suspension Make: \_\_\_\_\_

Suspension Model: \_\_\_\_\_

Tire Size: \_\_\_\_\_

\_\_\_\_\_ BT - From bottom of Axle to ground

\_\_\_\_\_ Z - Measurement between U-Bolts - Side-ways center of bolt to center of bolt.

\_\_\_\_\_ C - Measurement from center of outside U-Bolt to the bulge of tire (to do this drop a plumb-line down from center of U-Bolt, then measure straight across horizontally.)

\_\_\_\_\_ AD - Diameter of Axle

\_\_\_\_\_ Y - Measurement of U-Bolt center to center, from Front to Back.

\_\_\_\_\_ J - Measurement from bottom of air can assembly to ground. (if applicable)

\_\_\_\_\_ K - Measurement from center of axle to nearest point of Brake Can. (if applicable)